

Purchasing Department
Madison County Board of Supervisors
146 West Center Street
Canton, Mississippi 39046

601-855-5503
hardy@madison-co.com

11 May 2016

District 1 Supervisor Sheila Jones
District 2 Supervisor Trey Baxter
District 3 Supervisor Gerald Steen
District 4 Supervisor David Bishop
District 5 Supervisor Paul Griffin

Subject: Award Bid for Mini Excavators

Dear Board Members:

The board on April 18 approved Road Manager & County Engineer Dan Gaillet's request to exercise the three-year buyback agreement on two backhoes and to advertise for bids mini excavators to replace the backhoes. Bids were opened May 10 for the mini excavators. Copies of the bids and the bid tabulation are attached.

I recommend that the board take the following action:

1. Reject the low bid of \$75,133 from Puckett for a Caterpillar 307E2 due to the fact that it does not meet the specifications. The specifications require a minimum machine weight of 18,000 pounds; a Cat 307E2 weighs 16,028 pounds. The specifications require a net horsepower of 55; a Cat 307E2 has 50.6 HP. The specifications require a minimum stick length of 6 feet – 10 inches; a Cat 307E2 is 5 feet 6 inches. Incidentally, Puckett submitted a second bid on a Cat 308E2 CR SB that meets the specifications but was not the low bid.
2. Find that JWH's bid for two Case CX-80C mini excavators with five-year extended warranties at a price of \$86,973 each is the "lowest and best bid" and award said bid to JWH.

The total price for the two mini excavators is \$173,946. Madison County will receive a total of \$120,808 on the buyback of the two backhoes. The net cost to the county on the backhoes/mini excavators transaction will be \$53,138. The Road Department currently has \$157,973 available in its budget for equipment purchases. Following this transaction the Road Department will have \$104,835 remaining in its budget for equipment.

Sincerely,

Hardy Crunk
Purchase Clerk

	JWH CX-80C CASE	DEEP SOUTH 86C-1 JCB	PUCKETT 308 E 2 CRSB CAT	STRIBLING 85G DEERE	LYLE PC78US-10 KUBOTA	WILLIAMS TB290 TAKEUCHI	DEVINEY KX-080-4 KUBOTA	SCOTT VOLVO	PUCKETT 307 E 2 CAT REJECT DOES NOT MEET SPECS
CASH PRICE	84,119.00	83,500	94,923	99,950	97,000.00	89,497.20	\$84,972	\$98,589	75,133
3-YEAR EXTENDED WARRANTY	85,090.00	85,673	97,063	101,801	98,999.00	92,895.92	\$87,472	\$100,719	77,043
5-YEAR EXTENDED WARRANTY	86,973.00	89,182	98,653	105,040	100,760.00		\$89,472	\$102,859	78,163
3-YEAR BUYBACK	61,264.80	55,688	67,000	65,000	49,494.80	55,737.00			62,000
5-YEAR BUYBACK	53,923.26	44,591	54,000	45,000	38,289.00				50,000

BID SHEET

One or More New Mini Excavators

Bid Due Date: 10 A.M. 10 May 2016

Madison County Chancery Clerk's Office

Madison County Chancery Courthouse

Rooms 225-227, Second Floor

146 West Center Street, Canton, Mississippi 39046

(Any and All Information on Bid Sheet is Part of the Specifications)

TOTAL DELIVERED CASH PRICE: \$ 84,119

TOTAL DELIVERED CASH PRICE WITH FULL-MACHINE WARRENTY EXTENDED TO LESSER OF THREE YEARS OR 3,000 MACHINE HOURS:

\$ 85,090

TOTAL DELIVERED CASH PRICE WITH FULL-MACHINE WARRENTY EXTENDED TO LESSER OF FIVE YEARS OR 5,000 MACHINE HOURS:

\$ 86,973

GUARANTEED BUY BACK AT THE LESSER OF THREE YEARS OR 3,000 MACHINE HOURS:

\$ 61,264.80

GUARANTEED BUY BACK AT THE LESSER OF FIVE YEARS OR 5,000 MACHINE HOURS:

\$ 53,923.26

BID SHEET CONTINUED ON NEXT PAGE

NAME OF BIDDER: JWH Equipment

SIGNATURE OF BIDDER: W.E. / -

BIDDER'S ADDRESS: 1101 HWY 80 W

Jackson, MS 39204

BIDDER'S TELEPHONE NUMBER: 601-974-8090

BIDDER'S EMAIL ADDRESS: will@jwhequipment.com

ALL BIDS MUST BE SIGNED BY AUTHORIZED COMPANY REPRESENTATIVE

PRELIMINARY

ENGINE

Model	Isuzu AP-4LE2X,
Emissions Certification	Tier 4 Final
Fuel	Requires ultra low-sulfur fuel B5 biodiesel tolerant
Type	Water-cooled, 4-cycle, high pressure common rail system. Turbo-charged w/ air cooled intercooler, DPD system
Cylinders	4-cylinder in-line
Displacement	134 in ³ (2.2 L)
Bore/Stroke	3 x 4 in (85 x 96 mm)
Fuel injection	Direct injection – electronic
Fuel filter	Replaceable, full flow spin-on cartridge
Air filter	Dry type element w/ warning restriction indicator
Oil filter	Replaceable, full flow spin-on cartridge
Engine gradeability:	
Side-to-side	35°
Fore and aft	35°
Net horsepower – SAE J1349 @2000 RPM:	54 hp (40 kW)
Net max. torque – SAE J1349 @1800 RPM:	142 lb-ft (193 N-m)
Cooling operating range:	109.4° to -13° F (43° to -25° C)
Oil	Requires low-ash oil CJ-4

DRIVETRAIN

Travel control	Dual stage relief/ counter balance design
Brakes	Mechanical disc
Service brakes	SAHR disc – each motor
Two speed travel:	
Max. high speed	3.2 mph (5.1 kph)
Max. low speed	2.1 mph (3.3 kph)
Automatic downshift	
Drawbar pull	13,376 lb (59.5 kN)
Gradeability	70% – 35° slope

ELECTRICAL

Voltage	24 Volts
Alternator rating	50 amp
Batteries	2 x 12 Volt
Battery reserve capacity	64 Ah/5 hour
Work lights	24 Volt
1 boom	70 watt
1 upper	70 watt

OPERATOR ENVIRONMENT

FOPS Level 1 cab top guard; Pressurized cab; One-touch lock front window; AC/heat/defrost w/ auto climate control; 6 watt interior dome light; Mechanical-suspension cloth seat; Adjustable armrest; Low-effort joystick controls; Controls pre-wired for auxiliary; Blade control lever; AM/FM radio w/ antenna and 2 speakers; Anti-theft start code system; Rubber floor mat; 12-volt electric socket; 24-volt cigarette lighter; External rear view mirrors; Windshield wiper/washer; Cup holder; Storage compartments; Travel alarm w/ cancel switch; One key start and lock-up; Built-in full-color LCD monitor; Safety glass for all windows; Polycarbonate roof hatch.

Air conditioner output	13,490 BTU/hr
Heater output	12,900 BTU/hr
Sound level inside cab – ISO6395	73.0 dBA

ATTACHMENT

Boom	11 ft 6 in (3 500 mm)
Arm	5 ft 7 in (1 690 mm)
Bucket digging force	12,792 lbf (56.9 kN)

OPERATING WEIGHT

Operating weight	18,938 lb (8 590 kg)
w/ shoes	1 ft 6 in (450 mm)
w/ boom	11 ft 6 in (3 500 mm)
w/ arm	5 ft 7 in (1 690 mm)
w/ bucket	463 lb (210 kg)
w/ dozer blade	7 ft 7 in (2 320 mm)
w/ counterweight	2,425 lb (1 100 kg)

NOTE: w/ operator/full fuel/standard equipment

DOZER BLADE

Blade width	91.3 in (2 320 mm)
Blade height	17.7 in (450 mm)
Max. lift above ground level	17.3 in (440 mm)
Max. drop below ground	11.0 in (280 mm)

GROUND PRESSURE

@Standard operating weight 5.5 psi (0.38 bar)
w/ 23.6 in (600 mm) triple semi-grouser shoes

HYDRAULICS

System design	Open center
Main pumps	Two variable displacement/ axial piston
Max. rated flow	19.5 gpm (74 L/min)
System pressures:	
Boom, arm and bucket	4,264 psi (294 bar)
Travel circuits	4,264 psi (294 bar)
Swing circuits	3,278 psi (226 bar)

HYDRAULICS (cont.)

Pilot pump	1 x gear design
Max. capacity	4.8 gpm (18 L/min)
Controls	w/ boom/arm holding valve
Right track travel, bucket, boom and arm acceleration.	Four-spool section
Left track travel, bucket, boom and arm acceleration.	Five-spool section
Swing motor	Fixed displacement axial piston
Swing final drive	Planetary gear reduction
Travel motor	Two-speed independent travel/axial piston

HYDRAULIC CYLINDERS

Boom cylinders	Two (2)
Cylinder bore	4.5 in (115 mm)
Cylinder rod diameter	3.0 in (75 mm)
Cylinder stroke	33.5 in (850 mm)
Arm cylinder	One (1)
Cylinder bore	3.9 in (100 mm)
Cylinder rod diameter	2.6 in (65 mm)
Cylinder stroke	29.7 in (755 mm)
Bucket cylinder	One (1)
Cylinder bore	3.3 in (85 mm)
Cylinder rod diameter	2.2 in (55 mm)
Cylinder stroke	26.2 in (665 mm)

SERVICE CAPACITIES

Fuel tank	32 gal (120 L)
Hydraulic system	25 gal (96.3 L)
Hydraulic tank	13 gal (51 L)
Engine oil w/ filter	3 gal (11.5 L)
Swing drive	10.2 qt (9.7 L)
Final drive	1.2 qt (1.1 L)
Cooling system	3 gal (12.2 L)

OTHER SPECIFICATIONS

Swing speed	0 – 10.4 RPM
Swing torque	12,539 lb-ft (17 000 N-m)
Swing brake	Mechanical disc
Undercarriage:	
Length	9 ft 4 in (2 850 mm)
Track gauge	6 ft 2 in (1 870 mm)
Carrier rollers	1
Track rollers	5
Shoes – triple grouser	39
Shoe width – std.	1 ft 6 in (450 mm)
Link pitch	6.1 in (154 mm)
Track:	
Chain	Grease lubricated /strutted
Guides	Single
Adjustment	Hydraulic

BID SHEET

One or More New Mini Excavators

Bid Due Date: 10 A.M. 10 May 2016

Madison County Chancery Clerk's Office

Madison County Chancery Courthouse

Rooms 225-227, Second Floor

146 West Center Street, Canton, Mississippi 39046

(Any and All Information on Bid Sheet is Part of the Specifications)

TOTAL DELIVERED CASH PRICE: \$ 75,133⁰⁰ *Caterpillar 307E2*

TOTAL DELIVERED CASH PRICE WITH FULL-MACHINE WARRENTY EXTENDED TO LESSER OF THREE YEARS OR 3,000 MACHINE HOURS:

\$ 77,043.00

TOTAL DELIVERED CASH PRICE WITH FULL-MACHINE WARRENTY EXTENDED TO LESSER OF FIVE YEARS OR 5,000 MACHINE HOURS:

\$ 78,163.00

GUARANTEED BUY BACK AT THE LESSER OF THREE YEARS OR 3,000 MACHINE HOURS:

\$ 62,000⁰⁰

GUARANTEED BUY BACK AT THE LESSER OF FIVE YEARS OR 5,000 MACHINE HOURS:

\$ 50,000⁰⁰

BID SHEET CONTINUED ON NEXT PAGE

NAME OF BIDDER: Pockett Machinery Co.

SIGNATURE OF BIDDER: Kennon Ferguson

BIDDER'S ADDRESS: 100 Caterpillar Drive
Flowood Ms 39232

BIDDER'S TELEPHONE NUMBER: 601-969-6000

BIDDER'S EMAIL ADDRESS: Kennon.Ferguson@pockettmachinery.com

ALL BIDS MUST BE SIGNED BY AUTHORIZED COMPANY REPRESENTATIVE

STATE OF MISSISSIPPI
LICENSE NO. 1949
SENATE BILL NO. 2028
LAWS OF 1962
PRIVILEGE LICENSE NO. 5232



Cat[®] 307E2

MINI HYDRAULIC EXCAVATOR

Specifications

Engine

Engine Model	Cat [®] C2.4 Turbo*	
Rated Net Power @ 2,200 rpm		
ISO 9249/EEC 80/1269	37.7 kW	50.6 hp
Gross Power		
ISO 14396	39.6 kW	53.1 hp
Bore	87 mm	3.4 in
Stroke	102.4 mm	4.0 in
Displacement	2.4 L	146.5 in ³

*Meets U.S. EPA Tier 4 Final and EU Stage IIIB emission standards.

Weights

Operating Weight with Cab	7270 kg	16,028 lb
---------------------------	---------	-----------

18,000

- Weight with steel tracks with rubber pads, bucket, operator (75 kg/165 lb), full fuel and auxiliary lines.
- Weight varies depending on machine configuration.

Swing System

Machine Swing Speed	10.2 rpm
---------------------	----------

- Automatic swing break, spring applied, hydraulic release.

Travel System

Travel Speed		
High	5.1 km/h	3.17 mph
Low	3.2 km/h	1.99 mph
Maximum Traction Force		
High Speed	33.8 kN	7,599 lbf
Low Speed	59.3 kN	13,331 lbf
Gradeability (maximum)	20°	
Ground Pressure	33.9 kPa	4.92 psi

- Each track is driven by one independent 2-speed motor.
- Drive modules are integrated into the roller frame for total protection.
- Straight line travel when tracking and operating the front linkage simultaneously.

Service Refill Capacities

Fuel Tank	135 L	35.7 gal
Cooling System	14 L	3.7 gal
Engine Oil	11.0 L	2.9 gal
Hydraulic Tank	51 L	13.5 gal
Hydraulic System	78 L	20.6 gal

Hydraulic System

Pump Flow at 2,400 rpm	154 L/min	40.9 gal/min
Operating Pressure – Equipment	28 000 kPa	4,061 psi
Operating Pressure – Travel	28 000 kPa	4,061 psi
Operating Pressure – Swing	28 000 kPa	4,061 psi
Auxiliary Circuit – Primary (280 bar/4,061 psi)	128 L/min	33.8 gal/min
Auxiliary Circuit – Secondary (280 bar/4,061 psi)	33 L/min	8.7 gal/min
Digging Force – Stick (standard)	37.1 kN	8,340 lbf
Digging Force – Bucket	50.6 kN	11,375 lbf

- Load sensing hydraulics with variable displacement piston pump.

Blade

Width	2300 mm	90.6 in
Height	445 mm	17.5 in
Dig Depth	390 mm	15.3 in
Lift Height	350 mm	13.8 in

Cab

Average Exterior Sound Pressure	98 dB(A) ISO 6395 – Dynamic Test
---------------------------------	-------------------------------------

Operating Specifications

Stick Length – Standard	1670 mm	5 ft 6 in
Machine Overhang	358 mm	1 ft 2 in

307E2 Mini Hydraulic Excavator

Undercarriage

Number of Carrier Rollers	1 per side
Number of Track Rollers	5 per side
Track Roller Type	Center flange

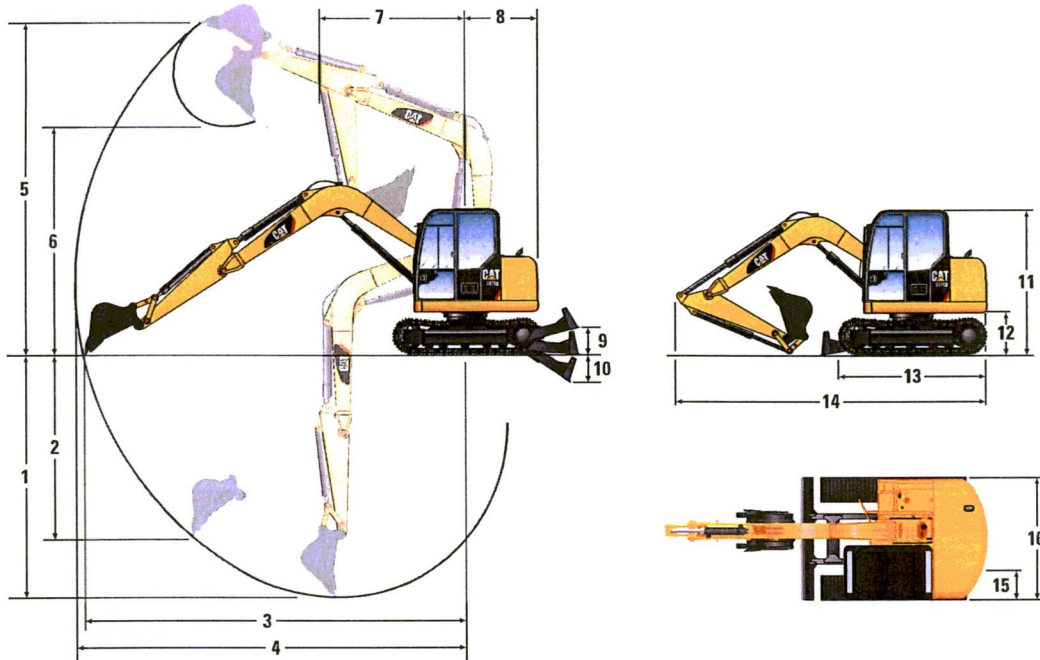

Dimensions

	Standard Stick	
1 Dig Depth	4070 mm	13'4"
2 Vertical Wall	3630 mm	11'11"
3 Maximum Reach at Ground Level	6160 mm	20'3"
4 Maximum Reach	6300 mm	20'8"
5 Maximum Dig Height	7240 mm	23'9"
6 Maximum Dump Clearance	5190 mm	17'3"
7 Boom In Reach	1690 mm	5'7"
8 Tail Swing (standard counterweight)	1750 mm	5'9"
9 Maximum Blade Height	390 mm	1'3"

	Standard Stick	
10 Maximum Blade Depth	350 mm	1'2"
11 Boom Height in Shipping Position	2630 mm	8'8"
O/A Shipping Height	2630 mm	8'8"
12 Swing Bearing Height	775 mm	2'7"
13 O/A Undercarriage Length	2760 mm	8'9"
14 O/A Shipping Length	6080 mm	19'11"
15 Track Belt/Shoe Width	450 mm	1'6"
16 O/A Track Width	2200 mm	7'3"

Lift Capacities at Ground Level (Standard Stick)*

Lift Point Radius		3000 mm (9'8")		4000 mm (13'1")		5000 mm (16'5")		5390 mm (17'8")	
		Front	Side	Front	Side	Front	Side	Front	Side
Blade Down	kg	3560	2410	2600	1520	2070	1120	1010	990
	lb	7,849	5,313	5,732	3,351	4,564	2,469	2,227	2,183
Blade Up	kg	2470	2120	1540	1350	1120	990	990	880
	lb	5,445	4,674	3,395	2,976	2,469	2,183	2,183	1,940

* The above loads are consistent with hydraulic excavator lift capacity rating standard ISO 10567:2007 and they do not exceed 87% of hydraulic lifting capacity or 75% of tipping capacity. The excavator bucket weight is not included on this chart. Lifting capacities are for standard stick.

307E2 Mini Hydraulic Excavator

STANDARD EQUIPMENT

- 1-way and 2-way (combined function) auxiliary hydraulic lines
- Adjustable auxiliary flow control for work tools
- Adjustable wrist rests
- Air suspension, heated seat
- Alternator
- AM/FM radio with auxiliary input
- Anti-theft security system
- Auto engine shut off
- Automatic engine idle
- Automatic swing park brake
- Automatic two speed travel
- Auxiliary line quick disconnects
- Boom and stick check valve (standard in Europe only)
- Boom mounted light – right side
- Cab mounted work light
- Cab, ROPS ISO 12117-2, A/C, heater/defroster, interior light and windshield wiper/washer
- Coat hook
- COMPASS display panel
- Cup holder
- Control pattern changer (not available in Europe)
- Continuous flow
- Dozer blade with float function
- Floor mat
- Foot travel pedals
- Footrest
- High ambient cooling (standard in all regions except Europe)
- Hydraulic oil cooler
- Hydraulic quick coupler lines
- Lifting eye on bucket linkage (optional in Europe)
- Low maintenance linkage pin joints
- Maintenance free battery
- Product Link™ ready
- Rain guard
- Rearview camera
- Rearview mirror
- Retractable seatbelt
- Secondary auxiliary hydraulic lines
- Site reference system
- “Thumb ready” stick
- Travel alarm (optional in Europe)

OPTIONAL EQUIPMENT

- Block heater
- Dual lock hydraulic coupler (available from dealer)
- Dual lock mechanical coupler (available from dealer)
- Ecology drain valve for hydraulic tank
- Front window mesh guard
- Front window steel bar guard
- Overhead guard (TOPGUARD Level 2)
- Track options:
 - Steel track – 450 mm (18 in)
 - Steel track with rubber pads – 450 mm (18 in)

BID SHEET

One or More New Mini Excavators

Bid Due Date: 10 A.M. 10 May 2016

Madison County Chancery Clerk's Office

Madison County Chancery Courthouse

Rooms 225-227, Second Floor

146 West Center Street, Canton, Mississippi 39046

(Any and All Information on Bid Sheet is Part of the Specifications)

TOTAL DELIVERED CASH PRICE: \$ 83,500.00

TOTAL DELIVERED CASH PRICE WITH FULL-MACHINE WARRENTY EXTENDED TO LESSER OF THREE YEARS OR 3,000 MACHINE HOURS:

\$ 85,673.00

TOTAL DELIVERED CASH PRICE WITH FULL-MACHINE WARRENTY EXTENDED TO LESSER OF FIVE YEARS OR 5,000 MACHINE HOURS:

\$ 89,182.00

GUARANTEED BUY BACK AT THE LESSER OF THREE YEARS OR 3,000 MACHINE HOURS:

\$ 55,688.00

GUARANTEED BUY BACK AT THE LESSER OF FIVE YEARS OR 5,000 MACHINE HOURS:

\$ 44,591.00

BID SHEET CONTINUED ON NEXT PAGE

NAME OF BIDDER: DEEP SOUTH EQUIPMENT

SIGNATURE OF BIDDER: Keith Goodin

BIDDER'S ADDRESS: 340 AIRPORT ROAD

JACKSON, MS 39208

BIDDER'S TELEPHONE NUMBER: 601-850-1303

BIDDER'S EMAIL ADDRESS: Keith.Goodin@DEEPSOUTHEQUIPMENT.COM

ALL BIDS MUST BE SIGNED BY AUTHORIZED COMPANY REPRESENTATIVE



Prepared For:
 MADISON COUNTY
 CANTON
 MS

fax:fax:

Dealer Information
 Deep South JCB
 340 Airport Road
 Jackson MS 39208
 phone:601-939-9655
 fax:601-939-9655

Prepared By:
 KEITH GOODIN
 keith.goodin@deepsouthequipment.com
 mobile:6018501303
 Quote Date: 05/09/16
 Valid Until: 06/03/16
 Quotation Reference: 126486

Model: 86C-1

Qty: 1

Stock Order/Serial No:2250141

86C-1 COMPACT EXCAVATOR BASE MACHINE (64.4 HP GROSS, KOHLER DIESEL 4 CYL. ENGINE)
 CAB WITH AIR CON: WITH JCB IMPACT PROTECTION GLASS
 18 IN (450 MM) RUBBER TRACKS: BRIDGESTONE
 ISO/SAE CONTROL PATTERN: HIGHFLOW; DOUBLE ACTING AUX CONTROLLED VIA RIGHT HAND JOYSTICK
 FABRIC SUSPENSION SEAT (HIGH BACK)
 AMERICAN LANGUAGE PACK: INCLUDES BATTERY ISOLATOR
 2100mm DIPPER: (FOR HIGH FLOWAUXILIARY ONLY)
 STANDARD DOZER (2320MM WIDE):FOR USE WITH 450mm TRACKS
 DOZER FLOAT SYSTEM
 LIVELINK
 TRAVEL ALARM KIT
 24" BUCKET
 HYDRAULIC THUMB

Equipment Total	83,500.00
Total Customer Sale Price	83,500.00

Optional Extras (Optional Extras are not included in the totals)

3 YEAR OR 3000 HOUR FULL MACHINE WARRANTY	2,173.00
5 YEAR OR 5000 HOUR FULL MACHINE WARRANTY	5,682.00

The above quote supersedes all preceding price quotes.

Customer Acceptance: _____

Date _____

Dealer _____

Date _____



BID SHEET

One or More New Mini Excavators

Bid Due Date: 10 A.M. 10 May 2016

Madison County Chancery Clerk's Office

Madison County Chancery Courthouse

Rooms 225-227, Second Floor

146 West Center Street, Canton, Mississippi 39046

(Any and All Information on Bid Sheet is Part of the Specifications)

TOTAL DELIVERED CASH PRICE:

\$ 94,923⁰⁰ Caterpillar 308E2

TOTAL DELIVERED CASH PRICE WITH FULL-MACHINE WARRENTY EXTENDED TO LESSER OF THREE YEARS OR 3,000 MACHINE HOURS:

\$ 97,063⁰⁰

TOTAL DELIVERED CASH PRICE WITH FULL-MACHINE WARRENTY EXTENDED TO LESSER OF FIVE YEARS OR 5,000 MACHINE HOURS:

\$ 98,653⁰⁰

GUARANTEED BUY BACK AT THE LESSER OF THREE YEARS OR 3,000 MACHINE HOURS:

\$ 67,000⁰⁰

GUARANTEED BUY BACK AT THE LESSER OF FIVE YEARS OR 5,000 MACHINE HOURS:

\$ 54,000⁰⁰

BID SHEET CONTINUED ON NEXT PAGE

NAME OF BIDDER: PUCKETT Machinery Co.

SIGNATURE OF BIDDER: Kennon Ferguson

BIDDER'S ADDRESS: 100 Caterpillar Dr.

Flowood MS 39232

BIDDER'S TELEPHONE NUMBER: 601-969-6000

BIDDER'S EMAIL ADDRESS: kennon.ferguson@Puckettmachinery.com

ALL BIDS MUST BE SIGNED BY AUTHORIZED COMPANY REPRESENTATIVE

STATE OF MISSISSIPPI
LICENSE NO. 1949
SENATE BILL NO. 2028
LAWS OF 1962
PRIVILEGE LICENSE NO. 5232



Cat[®]

308E2 CR SB

MINI HYDRAULIC EXCAVATOR
WITH SWING BOOM

Specifications

Engine

Engine Model	Cat C3.3B*	
Rated Net Power @ 2,400 rpm	ISO 9249/EEC 80/1269	
	48.5 kW	65 hp
Gross Power	ISO 14396	
	49.7 kW	66.6 hp
Bore	94 mm	3.7 in
Stroke	120 mm	4.7 in
Displacement	3.33 L	203.2 in ³

*Meets U.S. EPA Tier 4 Final and EU Stage IIIB emission standards.

Weights

Operating Weight with Cab	8400 kg	18,519 lb
---------------------------	---------	-----------

- Weight with rubber tracks, bucket, operator (75 kg/165 lb), full fuel and auxiliary lines.
- Weight varies depending on machine configuration.

Swing System

Machine Swing Speed	11 rpm	
Boom Swing – Left	60°	
Boom Swing – Right	50°	

- Automatic swing break, spring applied, hydraulic release.

Travel System

Travel Speed		
High	5.1 km/h	3.17 mph
Low	2.8 km/h	1.74 mph
Maximum Traction Force		
High Speed	64.5 kN	14,500 lb
Low Speed	37.4 kN	8,408 lb
Gradeability (maximum)	30°	
Ground Pressure	36.3 kPa	5.26 psi

- Each track is driven by one independent 2-speed motor.
- Drive modules are integrated into the roller frame for total protection.
- Straight line travel when tracking and operating the front linkage simultaneously.

Service Refill Capacities

Fuel Tank	125 L	33 gal
Cooling System	14 L	3.7 gal
Engine Oil	11.2 L	3.0 gal
Hydraulic Tank	82 L	21.7 gal
Hydraulic System	94 L	24.8 gal

Hydraulic System

Pump Flow at 2,000 rpm	150 L/min	39.6 gal/min
Operating Pressure – Equipment	28 000 kPa	4,061 psi
Operating Pressure – Travel	28 000 kPa	4,061 psi
Operating Pressure – Swing	24 000 kPa	3,481 psi
Auxiliary Circuit – Primary (186 bar/2,734 psi)	128 L/min	33.8 gal/min
Auxiliary Circuit – Secondary (174 bar/2,524 psi)	64 L/min	16.9 gal/min
Digging Force – Stick (standard)	40.1 kN	9,015 lb
Digging Force – Stick (long)	35.1 kN	7,891 lb
Digging Force – Bucket	60.2 kN	13,534 lb

- Load sensing hydraulics with variable displacement piston pump.

Blade

Width	2320 mm	91.3 in
Height	450 mm	17.7 in
Dig Depth	360 mm	14.2 in
Lift Height	380 mm	15.0 in

Cab

Dynamic Operator Sound Pressure	70 dB(A) ISO 6396	
Average Exterior Sound Pressure	99 dB(A) ISO 6395 – Dynamic Test	

Operating Specifications

Stick Length – Standard	1670 mm	5 ft 6 in
Stick Length – Long	2210 mm	7 ft 3 in
Machine Overhang	279.4 mm	11 in
Machine Overhang with Counterweight	406 mm	16 in
Counterweight	251 kg	551 lb



308E2 CR SB Mini Hydraulic Excavator with Swing Boom

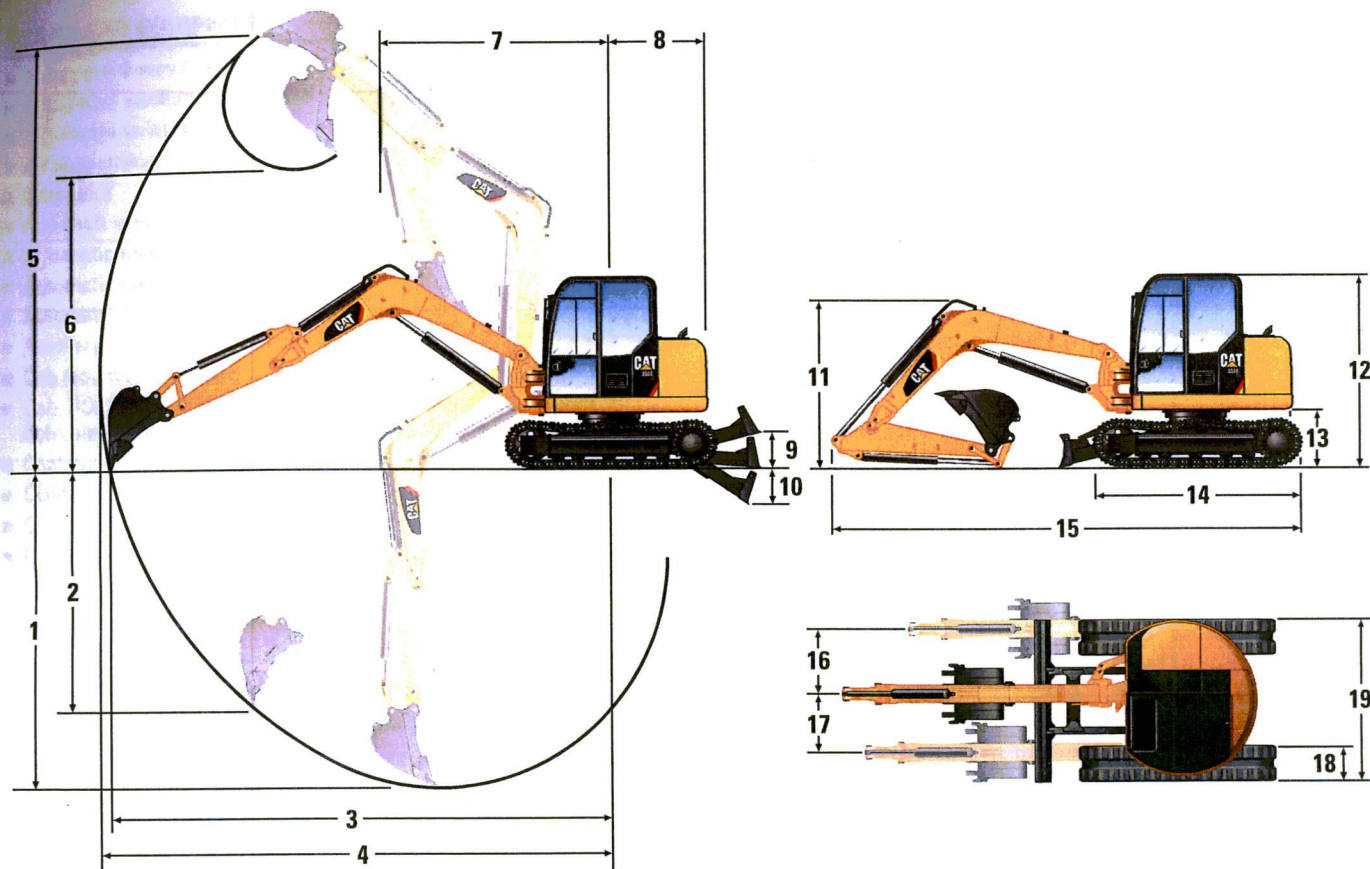

Dimensions

	Standard Stick		Long Stick	
1	4150 mm	13'7"	4690 mm	15'5"
2	2980 mm	9'9"	3550 mm	11'8"
3	6820 mm	22'9"	7350 mm	24'1"
4	7020 mm	23'0"	7540 mm	24'9"
5	6640 mm	21'9"	6990 mm	22'11"
6	4670 mm	15'4"	5010 mm	16'5"
7	2800 mm	9'2"	3280 mm	10'9"
8	1450 mm	4'9"	1450 mm	4'9"
9	420 mm	1'5"	420 mm	1'5"
10	320 mm	1'1"	320 mm	1'1"

	Standard Stick		Long Stick	
11	2280 mm	7'6"	2230 mm	7'4"
12	2550 mm	8'4"	2550 mm	8'4"
13	735 mm	2'5"	735 mm	2'5"
14	2903 mm	9'6"	2903 mm	9'6"
15	6380 mm	20'11"	6340 mm	20'10"
16	1010 mm	3'4"	1010 mm	3'4"
17	635 mm	2'1"	635 mm	2'1"
18	450 mm	1'6"	450 mm	1'6"
19	2320 mm	7'7"	2320 mm	7'7"

Lift Capacities at Ground Level*

Lift Point Radius		4000 mm (13'1")		6050 mm (19'10")	
		Front	Side	Front	Side
Blade Down	kg	3650	1710	1880	920
	lb	8,046	3,770	4,144	2,028
Blade Up	kg	1840	1530	970	820
	lb	4,056	3,373	2,138	1,808

* The above loads are consistent with hydraulic excavator lift capacity rating standard ISO 10567:2007 and they do not exceed 87% of hydraulic lifting capacity or 75% of tipping capacity. The excavator bucket weight is not included on this chart. Lifting capacities are for standard stick.

BID SHEET

One or More New Mini Excavators

Bid Due Date: 10 A.M. 10 May 2016

Madison County Chancery Clerk's Office

Madison County Chancery Courthouse

Rooms 225-227, Second Floor

146 West Center Street, Canton, Mississippi 39046

(Any and All Information on Bid Sheet is Part of the Specifications)

TOTAL DELIVERED CASH PRICE: \$ 99,950⁰⁰

TOTAL DELIVERED CASH PRICE WITH FULL-MACHINE WARRENTY EXTENDED TO LESSER OF THREE YEARS OR 3,000 MACHINE HOURS:

\$ 101,801⁰⁰

TOTAL DELIVERED CASH PRICE WITH FULL-MACHINE WARRENTY EXTENDED TO LESSER OF FIVE YEARS OR 5,000 MACHINE HOURS:

\$ 105,040.00

GUARANTEED BUY BACK AT THE LESSER OF THREE YEARS OR 3,000 MACHINE HOURS:

\$ 65,000⁰⁰

GUARANTEED BUY BACK AT THE LESSER OF FIVE YEARS OR 5,000 MACHINE HOURS:

\$ 45,000⁰⁰

BID SHEET CONTINUED ON NEXT PAGE

NAME OF BIDDER: STRIBLING EQUIPMENT, LLC

SIGNATURE OF BIDDER: Wayne Henry

BIDDER'S ADDRESS: P.O. Box 6038

JACKSON, MS 39288

BIDDER'S TELEPHONE NUMBER: 601-939-1000

BIDDER'S EMAIL ADDRESS: whenry@striblingequipment.com

ALL BIDS MUST BE SIGNED BY AUTHORIZED COMPANY REPRESENTATIVE

BID SHEET

One or More New Mini Excavators

Bid Due Date: 10 A.M. 10 May 2016

Madison County Chancery Clerk's Office

Madison County Chancery Courthouse

Rooms 225-227, Second Floor

146 West Center Street, Canton, Mississippi 39046

(Any and All Information on Bid Sheet is Part of the Specifications)

TOTAL DELIVERED CASH PRICE: \$ 97,000.00

TOTAL DELIVERED CASH PRICE WITH FULL-MACHINE WARRENTY EXTENDED TO LESSER OF THREE YEARS OR 3,000 MACHINE HOURS:

\$ 98,999.00

TOTAL DELIVERED CASH PRICE WITH FULL-MACHINE WARRENTY EXTENDED TO LESSER OF FIVE YEARS OR 5,000 MACHINE HOURS:

\$ 100,760.00

GUARANTEED BUY BACK AT THE LESSER OF THREE YEARS OR 3,000 MACHINE HOURS:

\$ 49,494.80

GUARANTEED BUY BACK AT THE LESSER OF FIVE YEARS OR 5,000 MACHINE HOURS:

\$ 38,289.00

BID SHEET CONTINUED ON NEXT PAGE

BID SHEET PAGE 2

NAME OF BIDDER: Lyle Machinery

SIGNATURE OF BIDDER: Sam S

BIDDER'S ADDRESS: 650 U.S. Hwy 49 South
Richard MS

BIDDER'S TELEPHONE NUMBER: 662-809-3888

BIDDER'S EMAIL ADDRESS: SSimmons@lylemachinery.com

ALL BIDS MUST BE SIGNED BY AUTHORIZED COMPANY REPRESENTATIVE

BID SHEET

One or More New Mini Excavators

Bid Due Date: 10 A.M. 10 May 2016

Madison County Chancery Clerk's Office

Madison County Chancery Courthouse

Rooms 225-227, Second Floor

146 West Center Street, Canton, Mississippi 39046

(Any and All Information on Bid Sheet is Part of the Specifications)

TOTAL DELIVERED CASH PRICE: \$ 89,497.20

TOTAL DELIVERED CASH PRICE WITH FULL-MACHINE WARRENTY EXTENDED TO LESSER OF THREE YEARS OR 3,000 MACHINE HOURS:

\$ 92,895.92

TOTAL DELIVERED CASH PRICE WITH FULL-MACHINE WARRENTY EXTENDED TO LESSER OF FIVE YEARS OR 5,000 MACHINE HOURS:

\$ N/A

GUARANTEED BUY BACK AT THE LESSER OF THREE YEARS OR 3,000 MACHINE HOURS:

\$ 55,737.00

GUARANTEED BUY BACK AT THE LESSER OF FIVE YEARS OR 5,000 MACHINE HOURS:

\$ N/A

BID SHEET CONTINUED ON NEXT PAGE

NAME OF BIDDER: Williams Equipment & Supply

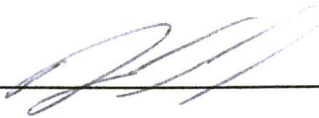
SIGNATURE OF BIDDER:  _____

BIDDER'S ADDRESS: 635 Hwy. 49 South

Richland, MS 39218

BIDDER'S TELEPHONE NUMBER: 601-906-9423

BIDDER'S EMAIL ADDRESS: jmware@williamsequipment.com

ALL BIDS MUST BE SIGNED BY AUTHORIZED COMPANY REPRESENTATIVE

BID SHEET

One or More New Mini Excavators

Bid Due Date: 10 A.M. 10 May 2016

Madison County Chancery Clerk's Office

Madison County Chancery Courthouse

Rooms 225-227, Second Floor

146 West Center Street, Canton, Mississippi 39046

(Any and All Information on Bid Sheet is Part of the Specifications)

TOTAL DELIVERED CASH PRICE: \$ 84,972.⁰⁰

TOTAL DELIVERED CASH PRICE WITH FULL-MACHINE WARRENTY EXTENDED TO LESSER OF THREE YEARS OR 3,000 MACHINE HOURS:

\$ 87,472.⁰⁰

TOTAL DELIVERED CASH PRICE WITH FULL-MACHINE WARRENTY EXTENDED TO LESSER OF FIVE YEARS OR 5,000 MACHINE HOURS:

\$ 89,472.⁰⁰

GUARANTEED BUY BACK AT THE LESSER OF THREE YEARS OR 3,000 MACHINE HOURS:

\$ n/a

GUARANTEED BUY BACK AT THE LESSER OF FIVE YEARS OR 5,000 MACHINE HOURS:

\$ n/a

BID SHEET CONTINUED ON NEXT PAGE

BID SHEET PAGE 2

NAME OF BIDDER: Devincy Rental & Supply / Jonathan McMillan

SIGNATURE OF BIDDER: 

BIDDER'S ADDRESS: 2173 Hwy 51A.

Madison MS - 38110

BIDDER'S TELEPHONE NUMBER: 601-855-0020

BIDDER'S EMAIL ADDRESS: jonathan@devincyrentalandsupply.com

ALL BIDS MUST BE SIGNED BY AUTHORIZED COMPANY REPRESENTATIVE

BID SHEET

One or More New Mini Excavators

Bid Due Date: 10 A.M. 10 May 2016

Madison County Chancery Clerk's Office

Madison County Chancery Courthouse

Rooms 225-227, Second Floor

146 West Center Street, Canton, Mississippi 39046

(Any and All Information on Bid Sheet is Part of the Specifications)

TOTAL DELIVERED CASH PRICE: \$ 98,589.⁰⁰

TOTAL DELIVERED CASH PRICE WITH FULL-MACHINE WARRENTY EXTENDED TO LESSER OF THREE YEARS OR 3,000 MACHINE HOURS:

\$ 100,719.⁰⁰

TOTAL DELIVERED CASH PRICE WITH FULL-MACHINE WARRENTY EXTENDED TO LESSER OF FIVE YEARS OR 5,000 MACHINE HOURS:

\$ 102,859.⁰⁰

GUARANTEED BUY BACK AT THE LESSER OF THREE YEARS OR 3,000 MACHINE HOURS:

\$ N/A

GUARANTEED BUY BACK AT THE LESSER OF FIVE YEARS OR 5,000 MACHINE HOURS:

\$ N/A

BID SHEET CONTINUED ON NEXT PAGE

NAME OF BIDDER: Scott Equipment Company

SIGNATURE OF BIDDER: 

BIDDER'S ADDRESS: 3860 - I-55 South

Jackson, MS 39212

BIDDER'S TELEPHONE NUMBER: 601-~~373~~ - 4600

BIDDER'S EMAIL ADDRESS: Msouthall@scottcompanies.com

ALL BIDS MUST BE SIGNED BY AUTHORIZED COMPANY REPRESENTATIVE